

KE-Series Constant-Wattage Heating Cable

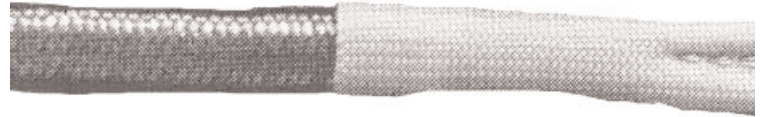

Installation Instructions



Read and understand this material before installing this heater. Failure to understand how to safely install the heater could result in an accident causing serious injury or death. This heater should only be installed by qualified personnel.

Tempco Electric Heater Corporation
607 N. Central Avenue
Wood Dale, IL 60191
www.tempco.com

Phone: 800-323-6859
630-350-2252
Fax: 630-0232
e-mail: info@tempco.com

Revised: 5/06

Introduction

Thank you for purchasing a Tempco KE Series constant-wattage heating cable system.

A heating cable system is a combination of heating cable, connection / termination kits, temperature controller, and accessories based on your particular application. Your heater is designed to provide a long and efficient service life with function, reliability, and safety in mind.

All Tempco Constant-Wattage Heating Cable utilize a parallel resistance modular design. This allows the heating cable to be cut to length and terminated in the field, without affecting the heating power per unit length. The modular design enables the cable terminations / electrical connections to be made with cold leads and cold ends (e.g. cable not heated in electrical junction box).

A temperature controller is required for all constant-wattage heating cable.

DANGER

A person who has not read and understood all installation instructions is not qualified to install this product.

WARNING

End User Must Comply to the Following:

- Only qualified personnel are allowed to connect the electrical wiring.
- Disconnect all supply power at the source before making any heating cable power input connections.
- All electrical wiring must follow local electrical codes and highly recommend following NEC Article 427.
- Final installation / wiring is to be inspected by the authority who has jurisdiction in the area that the heater is installed.
- The end-user is responsible for providing a suitable disconnecting device.
- The end-user is responsible for providing suitable electrical protection device. It is highly recommended that a ground fault circuit breaker be used.

DANGER

CAUTION

- Never handle the heater while it is in operation; always disconnect the heater from the power source and allow to cool prior to handling.
 - Inspect heater and connection kits before use.
 - Never operate heater without a temperature control device.
 - Do not wrap the heating cable over itself
 - If spillage of foreign matter onto heater occurs, disconnect from power source and clean after heater is allowed to cool
 - Never operate a heater without an appropriate heat sink (device being heated is considered a heat sink)
 - Do not operate heater above rated temperature value
 - Fasten heater to device using approved methods only
 - Do not repair damaged or faulty heaters.
 - Do not crush or apply severe physical stress on heater or cord assembly.
 - Disconnect heater when not in use.
- Failure to observe these warnings may result in personal injury or damage to the heater.

- Do not immerse heater in liquid.
- Keep volatile or combustible material away from heater when in use.
- Use heater only in approved locations
- Keep sharp metal objects away from heater.

Failure to observe these warnings may result in electric shock, risk of fire, and personal injury.

CONNECTION / TERMINATION KIT DESCRIPTIONS

**HTP90001: Universal Connection/
Termination Kit**

- 1 - 1" NPT Pipe standoff
- 2 - Ring terminals
- 3 - Wire nuts
- 3 - Lead pouches
- 2 - End pouches
- 1 - Caution label
- 1 - 3 oz. tube RTV sealant

Enough to complete:

Two end terminations and one power input connection, or one power input splice.

HTP90002: Lead/ End Termination Kit

- 5 - Lead pouches
- 5 - End pouches
- 1 - 3 oz. tube RTV sealant

Enough to complete:

Five lead and end terminations.

HTP90005: Splice Kit

- 3 - Lead pouches
- 1 - End pouch
- 3 - Crimp barrels
- 3 - Ring terminals
- 1 - 3 oz. Tube RTV sealant
- 1 - Caution label

Enough to complete:

One in-line splice or one tee splice.

Additional Required Hardware:

Wire nuts, pipe standoff, pipe straps, single hub junction box.

HTP90003: Lead Termination Kit

- 1-Lead pouch

Enough to complete: One lead termination.

HTP90004: End Termination Kit

- 1-End pouch

Enough to complete: One end termination.

Additional Hardware Required for Lead and End Kits:
RTV sealant.

Prior to Installation

STEP 1:

Check for suspected damage to heater like rips, punctures, etc. Ensure surface to be heated is free of jagged or sharp edges or weld splatter.

STEP 2:

Confirm all necessary installation hardware and tools are readily available. Depending on the application and kit, this may include...

Tools

Diagonal Cutter

Knife

Screwdriver

Crimping Tool / Wire Stripper

Measuring Tape/Ruler

Hardware and Accessories

Temperature Controller

Monitor Light Kit (Optional)

Aluminum or Fiberglass

Temperature Sensor

RTV Sealant

Adhesive Tape (verify

Connection / Termination Kits
(see kit descriptions to verify contents
and additional required hardware)

Pipe Straps

temperature rating)

Insulating Material

Junction Box

Heat Conductive Putty

Wire Nuts

Pipe Standoffs

Caution Labels

Pipe Reducer

STEP 3:

(A) Verify the total amperage of the system does not exceed the maximum amperage that the heating system components can handle.

(B) Verify that the total length of cable required does not exceed the maximum circuit length.

If the cable length exceeds (A) or (B), the cable must be divided into sections.

LEAD TERMINATION PREPARATION

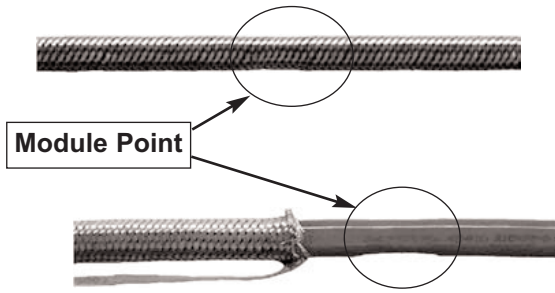

STEP 1:

Determine the module length of the heating cable. Module points can be identified by slight indentations on the rounded surface of the outer jacket. You can determine the module point by touch or visually by sliding back the metallic overbraid.

NOTE: KE series cable module points must be visually identified due to TEFLON® outer jacket.



STEP 2:

Cut the cable between the module points for the desired length of cold lead. The length of "cold lead" must be at least 12" (30.5cm) but no longer than the module length minus 6" (15.2cm). The section of cable between the end of the cable and the first module point will be the cold lead. This section will be used for lead termination / power input connection.



STEP 3:

Using a knife, remove 10" (25.4cm) of the outer jacket, exposing the metallic braid. **DO NOT DAMAGE THE BRAID.**



STEP 4:

Pull the metallic braid back over the end of the cable. Push the cable through the side of the metallic braid. Twist the empty braid to form a pigtail lead and crimp a ring terminal on the end (see picture above). A crimp barrel can also be used to extend the ground (braid) to another ground wire.



STEP 5:

Slide the metallic overbraid back at least an additional 4" (15.2cm). Using a knife, carefully cut and remove 4" (10.1cm) of the inner extruded jacket to expose the spirally wrapped resistance wire and the two bus wires. Do NOT damage the bus wires or the bus wire insulation; the resistance wire must NOT come into contact with the exposed bus wires. Unwrap and cut the resistance wire back to the point you cut the cable jacket.



STEP 6:

Fill a lead pouch with silicone RTV sealant. Slide the lead pouch over the two bus wires and over the inner wrap and outer most layer. Using wire strippers, remove 0.75" (1.9cm) of the insulation from the bus wires to expose the conductors. **DO NOT DAMAGE THE CONDUCTORS.**

END TERMINATION PREPARATION

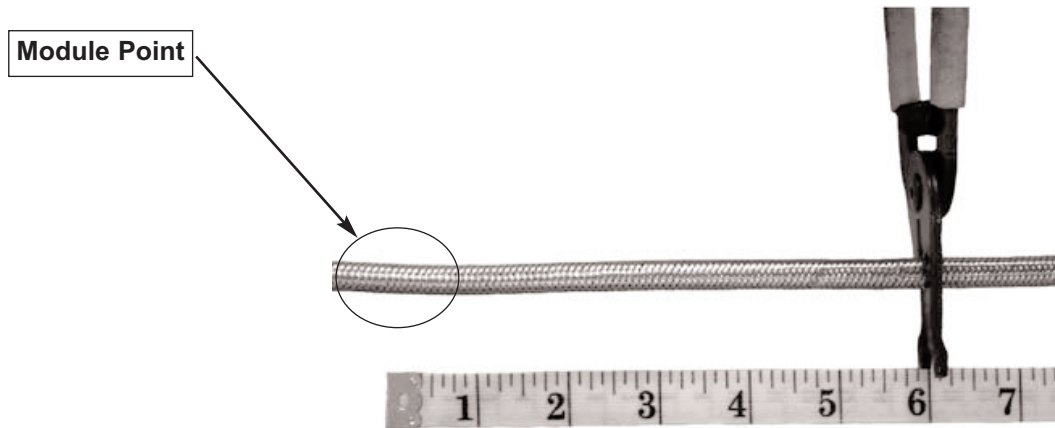

STEP 1:

Locate the last module point of the cable run. Cut the cable 6" (2.4cm) beyond this point to form a cold end.



STEP 2:

Using a knife, remove 2" (5cm) of the outer jacket, exposing the metallic braid. DO NOT DAMAGE THE BRAID.



STEP 3:

Fill an end pouch with silicone RTV sealant. Slide the filled end pouch over the two bus wires, innerjacket, and the outer most layer. Note: When attaching the heating cable to the pipe, make sure that the last module point is in contact with the pipe surface.

POWER INPUT CONNECTION INSTALLATION**⚠ WARNING**

Only authorized and trained personnel should perform the following procedure. The hazard of electrical shock exists with any electrical installation project. Disconnect all supply power at the source prior to making the heating cable power input connections.

⚠ CAUTION

A temperature controller is required for all constant-wattage heating cable.

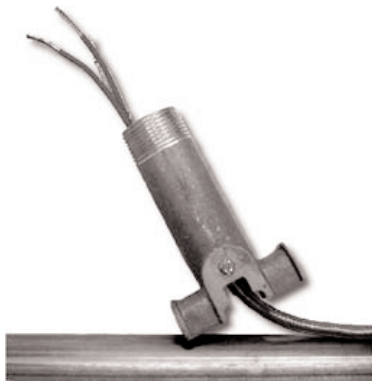
**STEP 1:**

Prepare heating cable end as specified under "Lead Termination Preparation". Insert approximately 8" (20cm) of the heating cable(s) through the bottom of the cast aluminum pipe standoff, making sure the first module point stays in contact with the pipe.

NOTE: A maximum of three cables fit through pipe standoff.

STEP 3:

Secure an appropriately sized junction box on the standoff. The standoff is supplied with a 1" NPT fitting. Pull the wiring through the associated fittings into the junction box and connect the heating cable(s) bus wires to the temperature controller with wire nuts. If applicable, secure the braided pigtail to the standoff with the ground screw or to the junction box with the panhead screw. Test the cable installation for continuity and insulation resistance. The insulation resistance between the bus wires and the metallic braid must be greater than 50 megohms at 500 volts. Close the junction box and attach the Caution Label to the cover of the junction box.

**STEP 2:**

Place the standoff on the pipe surface at the point where the supply wiring and associated fittings will connect to the pipe heat tracing cable. Fasten the standoff to the pipe with pipe straps. Fill the top of the standoff with Silicone RTV to provide a moisture seal between the pipe and electrical junction box. Make certain there are no voids between the cable and pipe standoff. Allow an appropriate amount of time for the Silicone RTV to cure.



SPLICE INSTALLATION**⚠ WARNING**

Only authorized and trained personnel should perform the following procedure. The hazard of electrical shock exists with any electrical installation project. Disconnect all supply power at the source prior to making the heating cable power input connections.

Step 1:

Prepare the heating cable ends to be spliced together as specified under "Lead Termination Preparation".

CAUTION: Never connect the two parallel conductors of the heating cable together.

STEP 2:

Insert the heating cable cold leads up through the pipe standoff and into the junction box. Attach the pipe standoff and junction box to the pipe where the splice is to be located. Fasten it with appropriately sized pipe clamps.

NOTE: A maximum of three cables fit through pipe standoff.

STEP 3:

Connect the leads of the heating cable ends together using wire nuts as shown in the illustrations. (wire nuts are not provided with HTP90001)

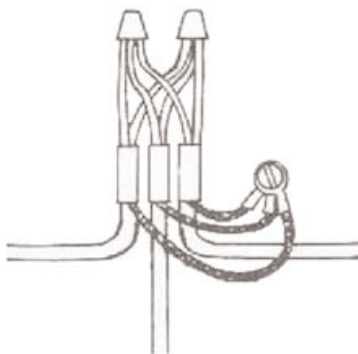

Tee Splice

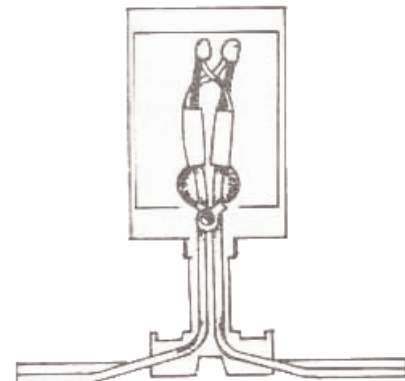

In Line Splice

STEP 4:

Connect the terminal lugs on the braid leads to a grounded screw on the pipe standoff or on the junction box.

NOTE: The junction box and pipe standoff must be grounded.

STEP 5:

Test the cable installation for continuity and insulation resistance. The insulation resistance between the bus wires and the metallic braid must be greater than 50 megohms at 500 volts. Close the junction box and attach the Caution Label to the cover of the junction box.

HEATING CABLE INSTALLATION

Cable Wrapping Techniques

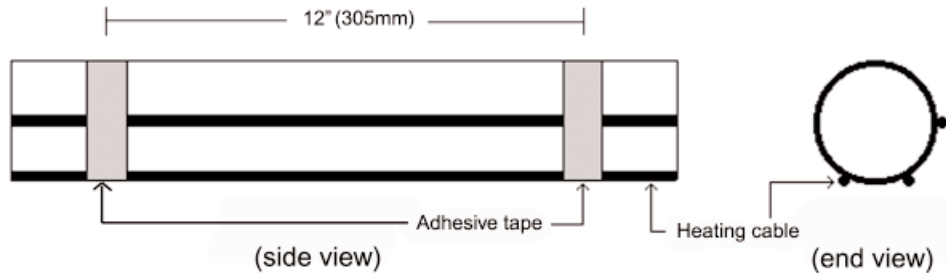

Straight run

A straight run is the simplest method to installing heating cable. It is possible to have multiple straight runs on a single object. With a single straight run, position cable at the bottom of a horizontal pipe.

CAUTION

Do not wrap the heating cable over itself or have two heating cables touch. All parts of heating cable must make intimate contact with surface to be heated. Use heat conductive putty to fill voids between cable and pipe surface. Wrap adhesive tape every 12" (305mm) around heating cable and pipe to attach the cable.

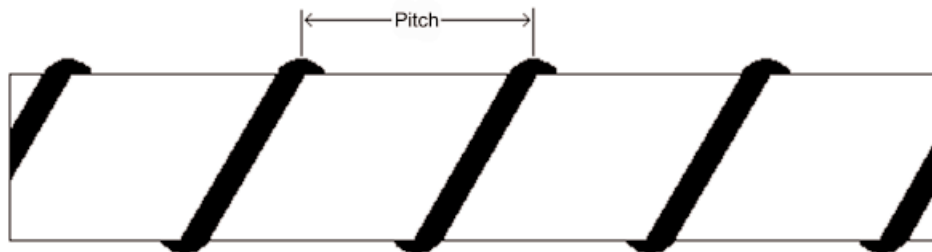

Spiral wrap

Spiral wrapping provides more heater coverage than a straight run. It can also require more heating cable. Verify the pitch length (see illustration) prior to installation to ensure you have enough heating cable to finish the job. If you need assistance in determining the pitch length, refer to the catalog example and pitch charts in Section 6 or call Tempco.

CAUTION

Do not wrap the heating cable over itself or have two heating cables touch. All parts of heating cable must make intimate contact with surface to be heated. Use heat conductive putty to fill voids between cable and pipe surface. Wrap adhesive tape every 12" (305mm) around heating cable and pipe to attach the cable.

Heating Cable Examples

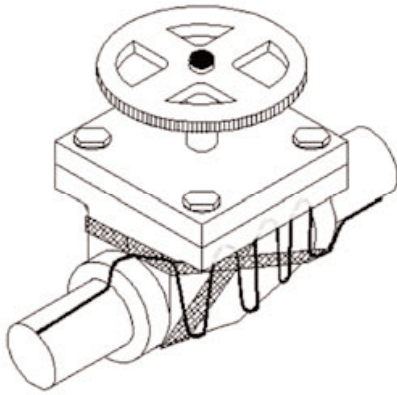

Valve

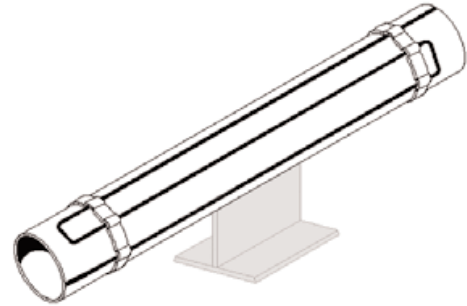

Pipe Support

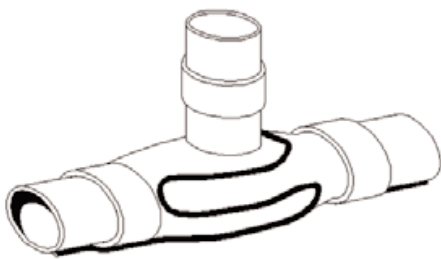

Blind Tee

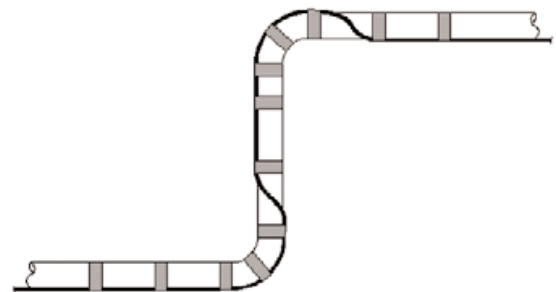

Elbow

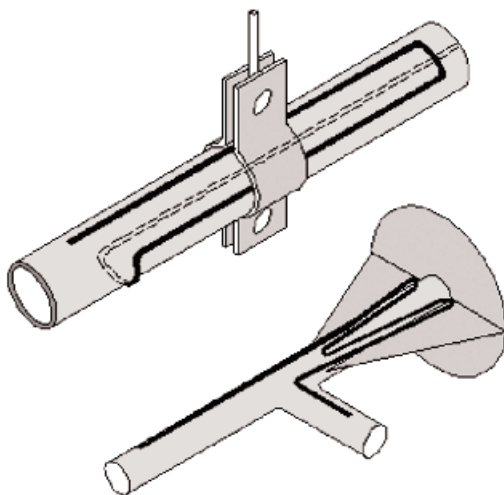

Support

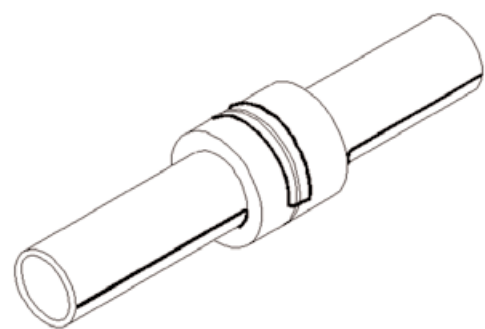

Flange Body

TROUBLESHOOTING GUIDE

Please read this guide prior to contacting Tempco. This guide is designed to answer the most commonly asked questions. If you are unable to identify the problem or need additional assistance, please contact Tempco at 1-800-323-6859 or e-mail techsupport@tempco.com

Problem	Solution
Entire heating cable run does not heat.	Verify heater is connected to proper voltage. Check to see if there is a resistance reading (not an open circuit) in heater using an ohm meter.
Portion of heating cable does not heat.	Examine unheated module for damage.
Circuit breaker is tripping.	Validate that the circuit breaker is capable of handling the amperage requirement of heater. Examine heater and power wiring for any damage. Verify open circuit exists between bus wire and ground braid.

WARRANTY INFORMATION

Tempco warrants to the original purchaser for the period of twelve (12) months from date of shipment or twelve (12) months from date of installation, whichever comes first. Contact factory at 1-800-323-6859 or 630-350-2252 for complete details.

Tempco Electric Heater Corporation
607 N. Central Avenue
Wood Dale, IL 60191
www.tempco.com

Phone: 800-323-6859
630-350-2252
Fax: 630-0232
e-mail: info@tempco.com